

**MODEL MANTA IV
CORE DRILL
OWNER'S MANUAL
PARTS LIST &
OPERATING
INSTRUCTIONS**



CAUTION

**READ SAFETY
AND GENERAL
INSTRUCTIONS
CAREFULLY
BEFORE USING
SAW FOR THE
FIRST TIME.**



**PLEASE RECORD THE SERIAL NUMBER OF
YOUR SAW IN THIS BLOCK.**

SERIAL NUMBER

**FOR YOUR ONE (1) YEAR WARRANTY TO
BE EFFECTIVE, COMPLETE THE WARRANTY
CARD (INCLUDE THE SERIAL NUMBER) AND
MAIL IT IN AS SOON AS POSSIBLE.**

Manual Part No. 164588
Revision 08/06

MK-MANTA IV

EXPLODED VIEW

MANTA IV CORE DRILL

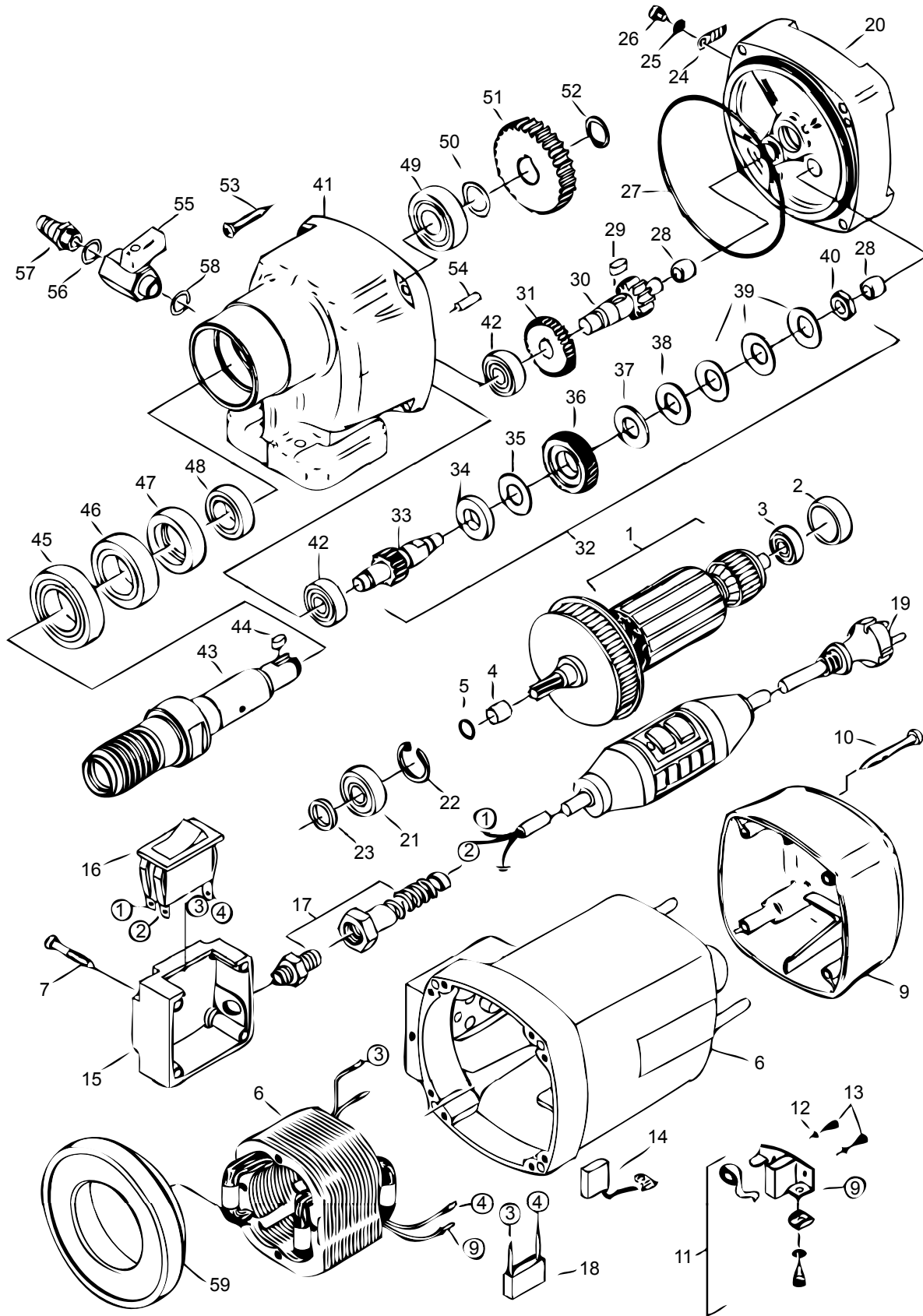

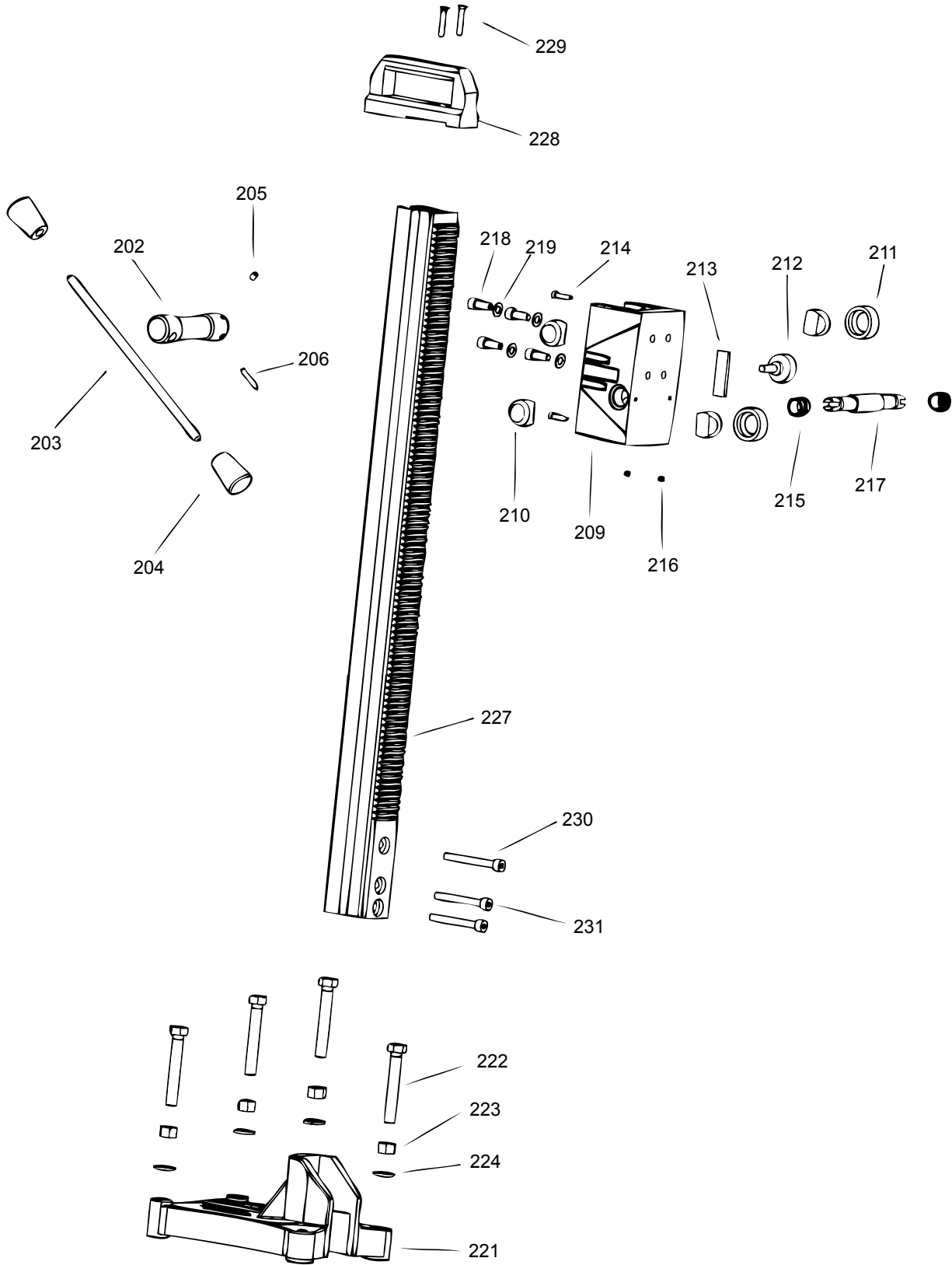

MANTA IV CORE DRILL PARTS LIST

PARTS LIST:

INDEX	DESCRIPTION	ITEM NO.	MK NO.
1	Rotor Complete	73631100	164447
2	Bearing Seal	73320315	164448
3	Ball Bearing See 100 579	80410021	164449
4	Bearing Ring	80420160	164450
5	C-Clip	80200748	164451
6	Field, 110 Volt	73511150	164452
7	Screw 4.2x16	80201292	164453
8	Motor Housing	73511200	164454
9	Cap	80900189	164455
10	Screw Replaces 050.0112	80201267	164295
11	Carbon Brush Holder	80201199	164283
12	Spring Disk 34	80201385	164456
13	Screw CM4x12	80201180	164457
14	Carbon Brush Replaces 8070019	80700040	160724
15	Switch Box	73511630	164458
16	Switch, ETA	80600157	164459
17	Cable Fitting	80600174	164460
18	Condenser-SEE #80500014	80500010	164479
19	Connecting Lead, 110 Volt for EBM 250/2P	73533262	164461
20	Transmission Bearing Plate	7B334610	164462
21	Bearing Replaces 80410101	107 832	164463
22	Locking Ring	80201351	164464
23	Shaft Seal	83000042	164465
24	Protective Grounding Connection	80601189	164466
25	Washer	80200752	164467
26	Screw	80201200	164468
27	O-Ring	83000092	164469
28	Needle Sleeve Replaces 050.0161	80420110	164302
29	Fitting Key	80200600	164470
30	Intermediate Shaft 2	73311500	164471
31	Idler Gear	73311470	164472
32	Clutch Complete	7B334493	164473
33	Intermediate Shaft 1	7B334490	164474
34	Thrust Washer	7B334499	164475
35	Clutch Washer	73331499	164476
36	Clutch Wheel	7B334550	164477
37	Disk	7332L499	164478
38	Driving Washer	73331496	164166
39	Spring Washer	80200716	160338
40	Nut, Hexagon 8m10 x 1	80201007	164069
41	Transmission Case	7B334400	164480
42	Bearing	80410020	164481
43	Spindle	73430420	164482
44	Parallel Key, Hardened	73430496	164483
45	Bearing	80410151	164484
46	Rotary Shaft Seal	83000072	164485
47	Shaft Seal	83000076	164486
48	Rotary Shaft Seal	83000162	164487
49	Bearing Replaces 050.0221	80410130	164488
50	Fitting Washer	80200507	164489

MANTA IV CORE DRILL PARTS LIST (cont...)

51	Spindle Wheel	73311430	164490
52	Snap Ring	80201323	164491
53	Tapping Screw	80201432	164492
54	Notched Pin 5x16	80200580	164493
55	Ball Valve, Mini	83000143	164494
56	Valve Ring-#52662&65205 #9 2126 0140 & 9 2126 0120	251 648	162852
57	Water Valve Replaces 83000124	256 573	164495
58	O-Ring	83000037	164496
59	Air Guiding Ring	73511141	164497
202	Handle Base	796UN740	164498
203	Arm	796UN746	164499
204	Knob	85000193	164500
205	Spring	85000157	164501
206	Pin	80200627	164502
209	Carriage	796UN792	164503
210	Bushing	796UN763	164504
211	Bushing Cap	796UN765	164505
212	Knob	85000158	164506
213	Clamping Piece	796UN779	164507
214	Screw	80201121	164508
215	Bushing	796UN770	164509
216	Set Screw	80200758	164510
217	Pinion	796UN730	164511
218	SCREW	80201147	164512
219	Lock Washer	80201309	164513
221	Base	796UN886	164514
222	Hexagon Screw	80201118	164515
223	Nut	80201014	164516
224	Washer	80201381	164517
227	Column	79620753	164518
228	Handle for Drill Stand	796UN816	164519
229	Screw	80201148	164520
230	SCREW, CYLINDER	80201156	164521
231	Screw	80201114	164522



MK Diamond Products, Inc.

1315 Storm Parkway. Torrance, CA 90509-2803
1 (800) 421-5830 FAX 1 (310) 539-5158

Part No. 164588
Revision 08/06